

Active high precision output signal conditioning module **FEATURES**

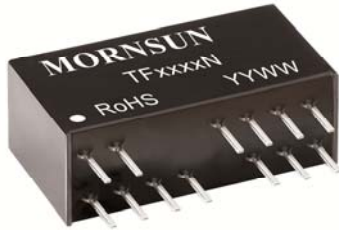

PART NUMBER SYSTEM

TFxxxxN



- Two-terminal isolation (signal input and signal output)
- High precision grade, High linearity (0.1% FS.)
- Isolation voltage (2KVAC/60s)
- Low ripple & noise: ($\leq 30\text{mVpp}$, 20MHz)
- Extremely low temperature drift ($\leq 50\text{PPM}/^\circ\text{C}$, within -40 to $+85^\circ\text{C}$)
- Small size: DIP18 ($26 \times 9.5 \times 12.5\text{mm}$)
- ESD protection (IEC/EN61000-4-2 Contact $\pm 4\text{KV}$ perf. Criteria B)

The TFxxxxN series is with preceding voltage signal input and backward voltage/current signal output, and with an inner high efficiency isolated micro-power source. It can provide isolation power to peripheral circuit at the same time of providing power to internal signal processing circuit. Adopting electromagnetism isolation technology, therefore compared with photo-coupler isolation, it has higher accuracy and lower temperature drift. This module is two-port isolation (input and output). There are external functions for the series as zeros and full adjustment, convenient for customer to design and adjust.

Selection Guide

Model	Power Supply input (VDC)	Input Signal	Output Signal	Isolation Power Output (VDC)
TF5134N	24	0~10V	4~20mA	15
TF5234N	24	0~10V	0~20mA	15
TF5534N	24	0~10V	0~10V	15
TF5554N	12	0~10V	0~10V	15
TF5634N	24	0~10V	0~5V	15
TF6134N	24	0~5V	4~20mA	15
TF6234N	24	0~5V	0~20mA	15
TF6250N	12	0~5V	0~20mA	None
TF6254N	12	0~5V	0~20mA	15
TF6664N	5	0~5V	0~5V	15
TFS160N-3.3	5	0~3.3V	4~20mA	None

Input Specifications

Item	Operating Conditions	Value	
Power Input	Input voltage	(Nominal value of power supply input) $\pm 5\%$	
	Input power	Isolation power output, Voltage output	$\leq 1.5\text{W}$
		Isolation power output, Current output	$\leq 2.0\text{W}$
	Power supply protection	Reverse polarity protection	
Single Input*	Input signal	See selection guide	
	Input impedance	in case of max. input of voltage signal	$\geq 10\text{M}\Omega$
	Overload	in case of input of voltage signal	$\leq 30\text{V}$

Note: * When the input signal is open, if the output signal value need near 0, please connect a resistor ($< 100\text{K}\Omega$) in parallel at the signal input port (near one end of the model).

Output Specifications

Item	Operating Conditions	Value
Isolation Power Output	Output voltage	(Nominal value) $\pm 10\%$
	Output current	$\leq 25\text{mA}$

Single Output	Output signal		See selection guide
	Load capacity	Current output	≤500Ω
		Voltage output	≥2KΩ
Ripple & noise	20MHz Bandwidth	≤30mVpp	

Transmission Specifications

Item	Operating Conditions	Value
Zero Offset	Ta=25°C	0.1%F.S.
Signal Precision	Ta=25°C	0.1%F.S.
Temperature Drift	Operating temperature range of -40 to +85°C	≤50PPM/°C
Adjustable Function	Full Degree Regulation	Can be adjusted within ±5% output signal range
	Zero Regulation	Can be adjusted within ±5% output signal range
Bandwidth		≥2KHz
Response Time		≤1ms

General Specifications

Item	Operating Conditions	Value
Electric Isolation		Isolated between the signal input and the signal output.
Degree of Isolation	testing for 1 minute, leakage current <1mA, humidity <70%	2KVAC
Isolation Resistance	500VDC	100MΩ
Operating Temperature		-40~+85°C
Transportation and Storage Temperature		-50~+105°C
Application Environment		The presence of dust, fierce vibration, impulsion and corrosive gas may cause damage to the product

Physical Specifications

Casing Material	Black flame-retardant heat-proof plastic
Package	DIP18
Weight	5.7g(Typ.)
Cooling Method	Natural cooling

EMC Specifications

EMI	CE	CISPR22/EN55022	CLASS A (see Fig. 4 for recommended circuit)	
EMS	ESD	IEC/EN61000-4-2	Contact ±4KV	perf. Criteria B
	EFT	IEC/EN61000-4-4	Power supply port ±2KV (see Fig. 4 for recommended circuit)	perf. Criteria B
	Surge	IEC/EN61000-4-5	Power supply ±1KV (see Fig. 4 for recommended circuit)	perf. Criteria B

Application Precautions

1. Please read the instructions carefully before use; contact our technical support if you have any problem.
2. Do not use the product in hazardous areas.
3. Use DC power supply for the product and 220V AC power supply is prohibited.
4. Do not dismount and assemble the product without permission to avoid failure or malfunction of equipment.

After-sales service

1. Ex-factory inspection and quality control have been strictly conducted for the product; if there occurs abnormal operation or possibility of failure of internal module, please contact the local representative or our technical support.
2. The warranty period for the product is 3 years as calculated from the date of delivery. If any quality problem occurs under normal use within the warranty period, the product can be repaired or changed for free.

Applied circuit

See *Application Notes for Isolated Transmitter* for details.

Design Reference

1. Typical application

1) Schematic diagram

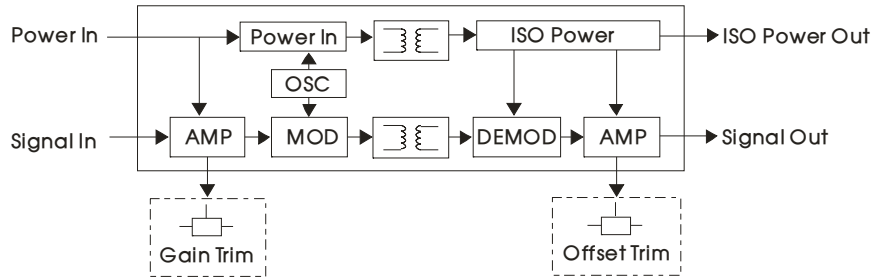

Fig. 1

2) Typical application—Isolation application of AO board card in DCS system

Application circuit for typical multi-channel signal acquisition is as below:

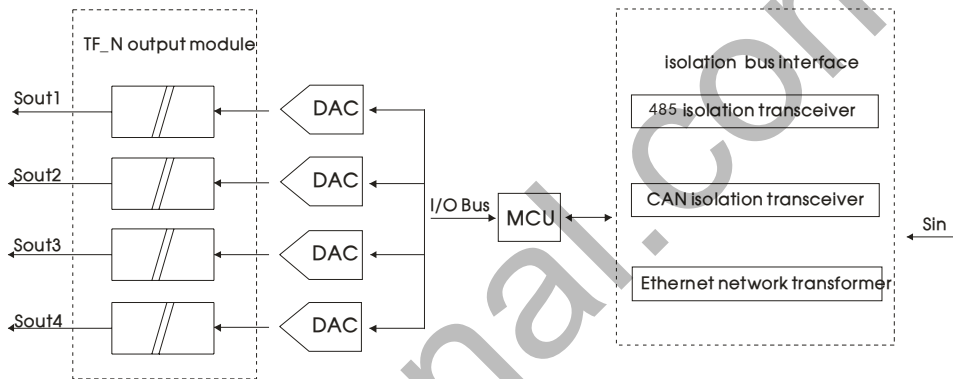

Fig. 2 Isolation application figure of AO board card in DCS system

Function

In the figure 2, Sin are input signals for peripheral circuit. The input signals can be sent to MCU and isolated with Sin by 485 isolation transceiver, CAN isolation transceiver and Ethernet network transformer, MCU control system receive the signals, and output digital signals after signal processing. DAC is digital to analog converter, digital signals can be transferred to analog signals by DAC. TF_N output module isolation output the analog signals transferred from DAC. Sout1, Sout2, Sout3 and Sout4 are multiplex output isolation signals.

Working principle

When the circuit works, peripheral circuit provides input signals Sin, and it transfers input signals to MCU control system by isolated bus interface. The MCU receives the signals and manage them, then output digital signals. The digital signals are transferred by I/O bus. Digital signals are converted to analog signals through DAC. After these analog signals get through TF_N output module, we can get isolation signals. The whole working process realizes that the inner signals of control system are isolated with the peripheral circuit and the output signals, Sout1, Sout2, Sout3 and Sout4 are isolated and not interfere with each other.

3) Application—Zero and full adjustment function

Zero and full adjustment recommended setting circuit is as shown

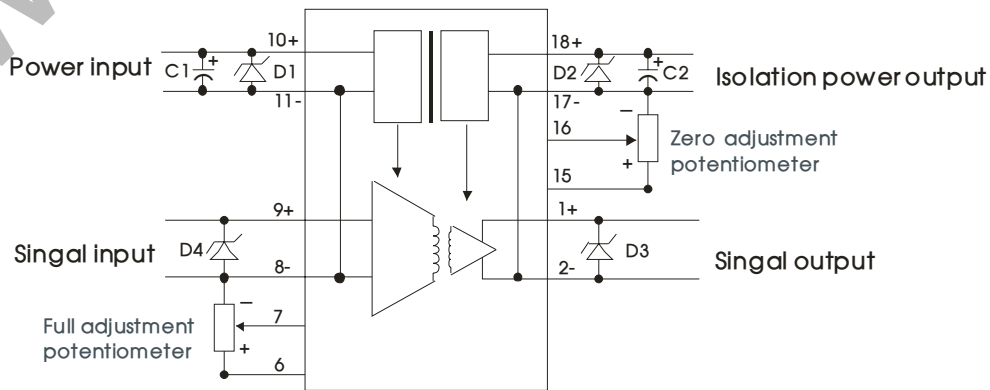

Fig. 3 Zero and full adjustment circuit

Function

Zero adjustment function by setting up adjustment resistor at the zero point can change the zero signal transmission, which makes the output signal overall migration. Full adjustment function is also called the gain adjustment function, and it can change the ratio of signal transmission through the set up corresponding adjust resistance at the full adjustment, and the isolation transmission proportion of input and output signal value would be changed.

Usage

Adding and reducing negative zero resistance can reduce the zero of signal output. Adding and reducing positive zero resistance can increase the zero of signal output. Adding and reducing negative full adjustable resistance can reduce the ratio of signal transmission, Adding and reducing positive full adjustable resistance can increase the ratio of signal transmission. You can use potentiometer to adjust the output signal of zero and full in practical application. As shown in the figure 3, the terminal of full or zero adjustment is connected to the sliding of potentiometer, and the both ends of potentiometer is to the zero or full reference of positive and negative regulating reference . Sliding potentiometer to adjust signal full or changing the ratio of rise and fall can also adjust zero and full of the output signal.

As shown in the figure 3, Adjusting the potentiometer to positive can increase zero or full of the corresponding signal. Adjusting the potentiometer to negative can reduce zero or full of the corresponding signal. The maximum recommended range of potentiometer is $10K\Omega \sim 1M\Omega$, detail resistance selection according to the adjustment accuracy. Choose larger resistance potentiometer for high precision fine-tuning. Choose smaller resistance potentiometer for a wide range of rough adjustment.

Notice

Using the function of zero and full adjustment will affect original accuracy. Due to the effect on temperature drift of external adjustment resistor and the stability of the potentiometer, temperature drift of product will be changed, too. For the zero and full adjustment potentiometer, the ratio between positive resistance and negative resistance, which makes the zero point of different products predetermined Zero point is diverse. Please set the value of potentiometer according to actual situation.

2. Recommended EMC circuit

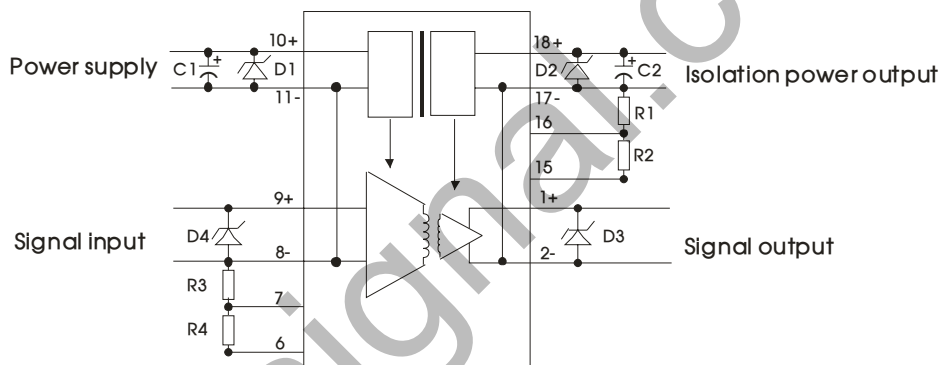
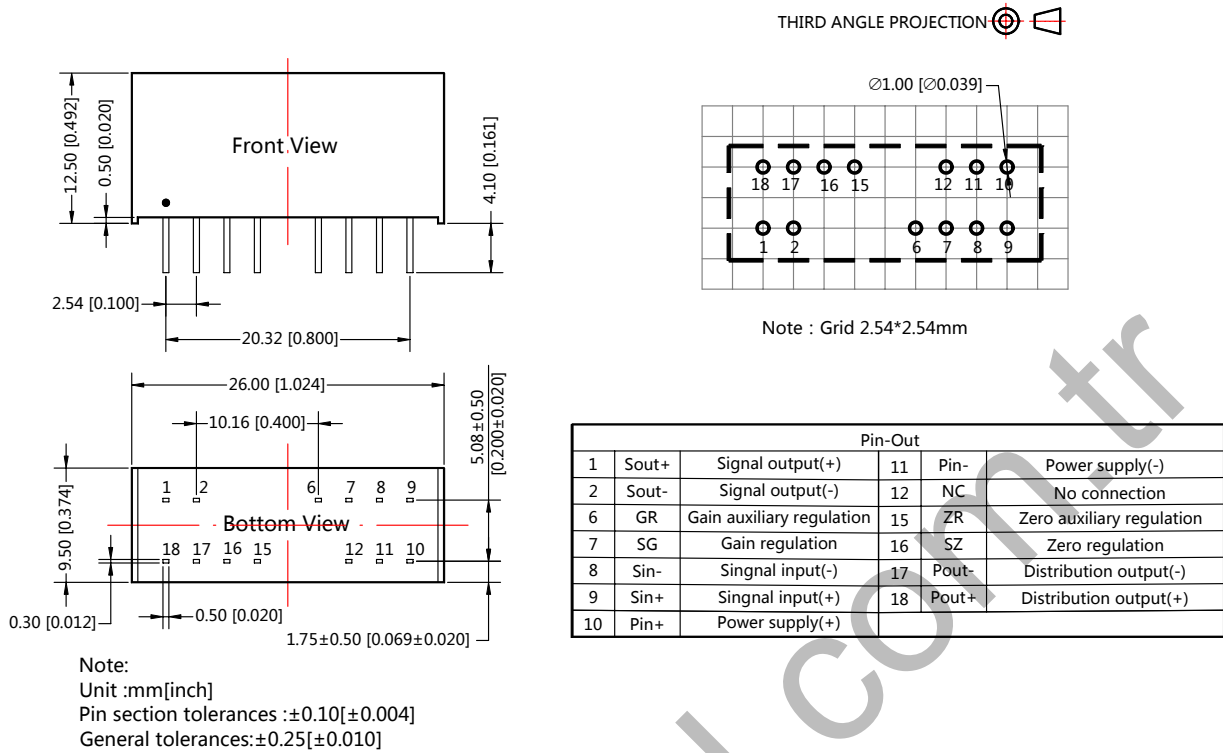

Fig. 4

Components	Recommended parameters
C1	100uF/35V
C2	4.7uF/35V
R1	Negative zero adjustment resistance
R2	Positive zero adjustment resistance
R3	Negative gain adjustment resistance
R4	Positive gain adjustment resistance
D1	SMCJ28A
D2	SMCJ30A
D3	SMBJ15A
D4	SMBJ15A

2. For more information please find the application notes on www.mornsun-power.com

Dimensions and Recommended Layout



Notes:

1. Packing Information please refer to 'Product Packing Information'. Packing bag number: 58240002;
2. Unless otherwise specified, data in this datasheet should be tested under the conditions of Ta=25°C, humidity<75% when inputting nominal voltage and outputting rated load;
3. All index testing methods in this datasheet are based on our Company's corporate standards;
4. The performance indexes of the product models listed in this datasheet are as above, but some indexes of non-standard model products will exceed the above-mentioned requirements, and please directly contact our technician for specific information;
5. We can provide product customization service;
6. Specifications of this product are subject to changes without prior notice.

Mornsun Guangzhou Science & Technology Co., Ltd.

Address: No. 5, Kehui St. 1, Kehui Development Center, Science Ave., Guangzhou Science City, Luogang District, Guangzhou, P. R. China
Tel: 86-20-38601850-8801 Fax: 86-20-38601272 E-mail: info@mornsun.cn