

# DATA SHEET

**E65/32/27**

**E cores and accessories**

Supersedes data of September 2004

2008 Sep 01



**FERROXCUBE**  
A YAGEO COMPANY

**CORE SETS**

**Effective core parameters**

SYMBOL	PARAMETER	VALUE	UNIT
$\Sigma(l/A)$	core factor (C1)	0.274	mm <sup>-1</sup>
$V_e$	effective volume	79000	mm <sup>3</sup>
$l_e$	effective length	147	mm
$A_e$	effective area	540	mm <sup>2</sup>
$A_{min}$	minimum area	530	mm <sup>2</sup>
m	mass of core half	≈205	g

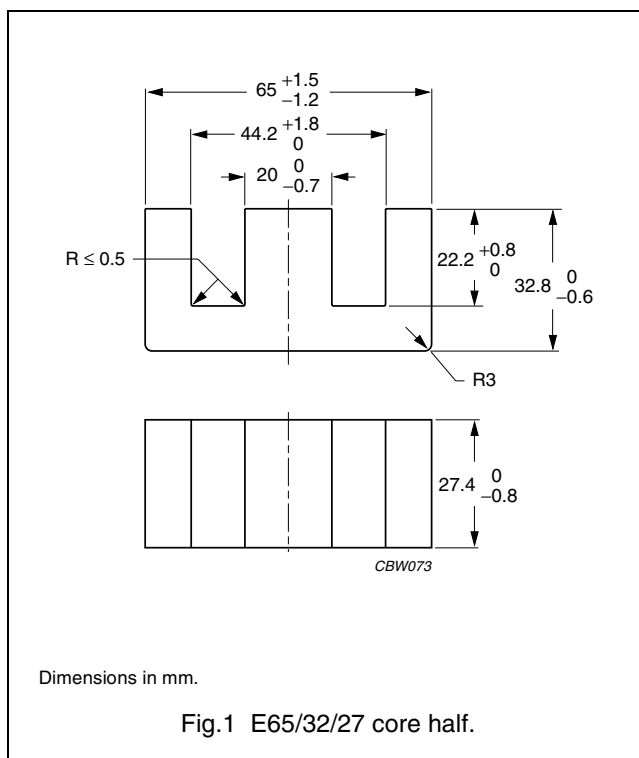

**Core halves**

$A_L$  measured in combination with a non-gapped core half, clamping force for  $A_L$  measurements 60 ±20 N, unless stated otherwise.

GRADE	$A_L$ (nH)	$\mu_e$	TOTAL AIR GAP (μm)	TYPE NUMBER
3C90	100 ±5% <sup>(1)</sup>	≈ 22	≈ 14380	E65/32/27-3C90-E100
	160 ±5% <sup>(1)</sup>	≈ 35	≈ 7560	E65/32/27-3C90-E160
	250 ±5% <sup>(1)</sup>	≈ 54	≈ 4100	E65/32/27-3C90-E250
	315 ±5% <sup>(1)</sup>	≈ 68	≈ 3020	E65/32/27-3C90-E315
	400 ±8% <sup>(1)</sup>	≈ 87	≈ 2200	E65/32/27-3C90-E400
	630 ±10% <sup>(1)</sup>	≈ 136	≈ 1240	E65/32/27-3C90-E630
	8600 ±25%	≈ 1860	≈ 0	E65/32/27-3C90
3C92 <b>des</b>	6000 ±25%	≈ 1310	≈ 0	E65/32/27-3C92
3C94	8600 ±25%	≈ 1860	≈ 0	E65/32/27-3C94
3C95 <b>des</b>	10600 ±25%	≈ 2300	≈ 0	E65/32/27-3C95
3F3	100 ±5% <sup>(1)</sup>	≈ 22	≈ 14380	E65/32/27-3F3-E100
	160 ±5% <sup>(1)</sup>	≈ 35	≈ 7560	E65/32/27-3F3-E160
	250 ±5% <sup>(1)</sup>	≈ 54	≈ 4100	E65/32/27-3F3-E250
	315 ±5% <sup>(1)</sup>	≈ 68	≈ 3020	E65/32/27-3F3-E315
	400 ±8% <sup>(1)</sup>	≈ 87	≈ 2200	E65/32/27-3F3-E400
	630 ±10% <sup>(1)</sup>	≈ 136	≈ 1240	E65/32/27-3F3-E630
	7300 ±25%	≈ 1580	≈ 0	E65/32/27-3F3

**Note**

1. Measured in combination with an equal gapped core half.

## E cores and accessories

E65/32/27

**Core halves of high permeability grades**Clamping force for  $A_L$  measurements,  $60 \pm 20$  N.

GRADE	$A_L$ (nH)	$\mu_e$	AIR GAP ( $\mu\text{m}$ )	TYPE NUMBER
3C11	$16700 \pm 25\%$	$\approx 3620$	$\approx 0$	E65/32/27-3C11

**Properties of core sets under power conditions**

GRADE	B (mT) at	CORE LOSS (W) at				
	H = 250 A/m; f = 25 kHz; T = 100 °C	f = 25 kHz; $\hat{B} = 200$ mT; T = 100 °C	f = 100 kHz; $\hat{B} = 100$ mT; T = 100 °C	f = 100 kHz; $\hat{B} = 200$ mT; T = 25 °C	f = 100 kHz; $\hat{B} = 200$ mT; T = 100 °C	f = 400 kHz; $\hat{B} = 50$ mT; T = 100 °C
3C90	$\geq 320$	$\leq 9.1$	$\leq 12$	–	–	–
3C92	$\geq 370$	–	$\leq 8.5$	–	$\leq 47$	–
3C94	$\geq 320$	–	$\leq 8.5$	–	$\leq 47$	–
3C95	$\geq 320$	–	–	$\leq 49.8$	$\leq 47.4$	–
3F3	$\geq 320$	–	$\leq 10.5$	–	–	$\leq 21$

**COIL FORMER**

**General data for E65/32/27 coil former without pins**

PARAMETER	SPECIFICATION
Coil former material	polyethylene terephthalate (PET), glass reinforced, flame retardant in accordance with "UL 94V-0"; UL file number E107536
Maximum operating temperature	130 °C, "IEC 60085", class B

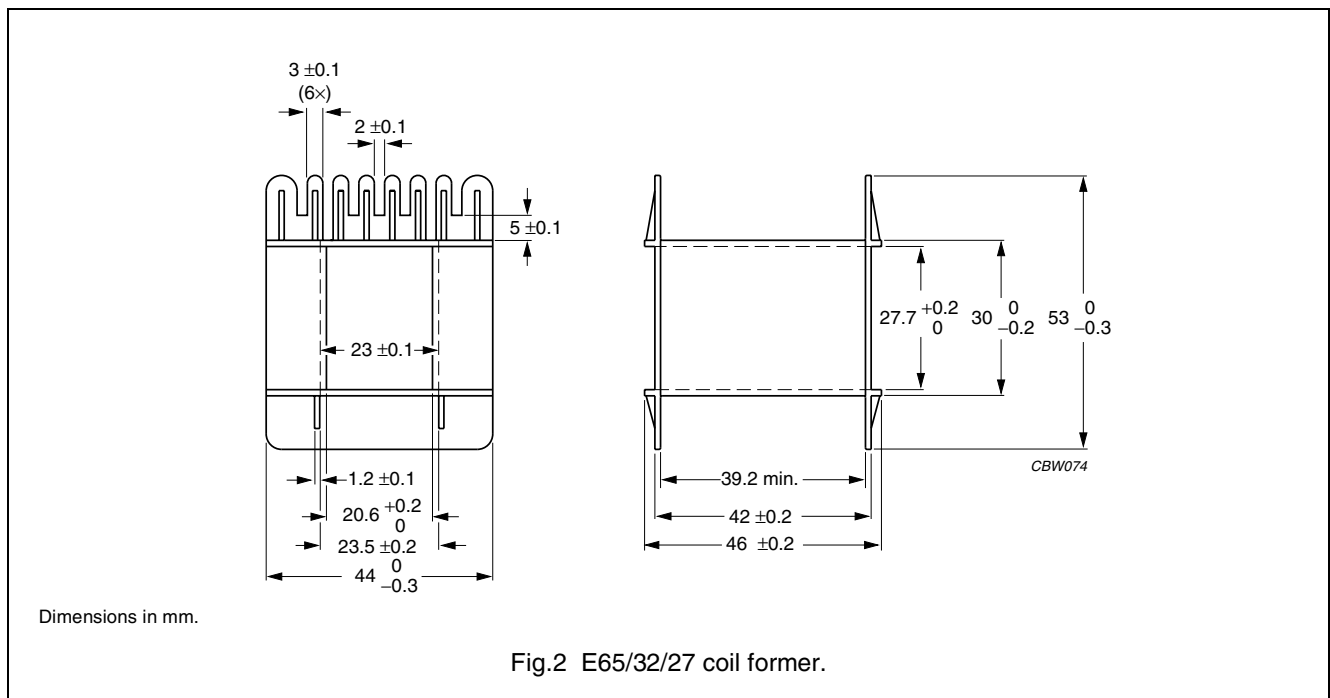

**Winding data and area product for E65/32/27 coil former without pins (E)**

NUMBER OF SECTIONS	MINIMUM WINDING AREA (mm <sup>2</sup> )	NOMINAL WINDING WIDTH (mm)	AVERAGE LENGTH OF TURN (mm)	AREA PRODUCT Ae x Aw (mm <sup>4</sup> )	TYPE NUMBER
1	394	39.2	150	213000	CP-E65-1S-T

**MOUNTING PARTS**

**General data for mounting parts**

ITEM	REMARKS	FIGURE	TYPE NUMBER
Clasp	steel, zinc (Zn) plated	3	CLA-E65/32/27
Spring	steel, zinc (Zn) plated	4	SPR-E65/32/27

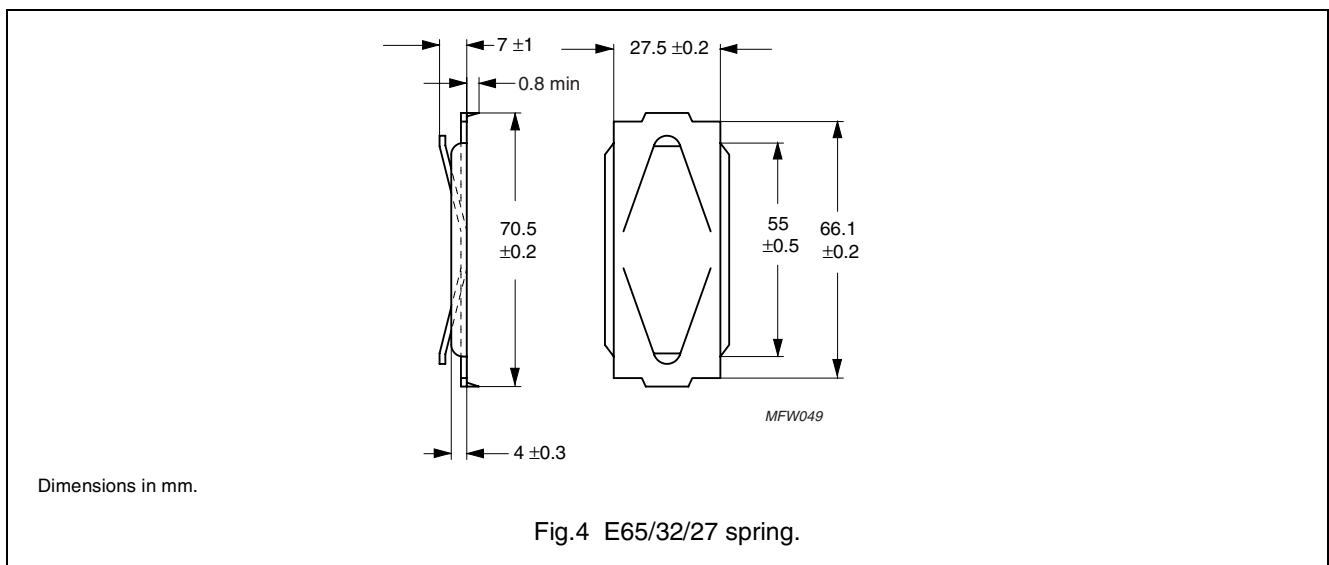
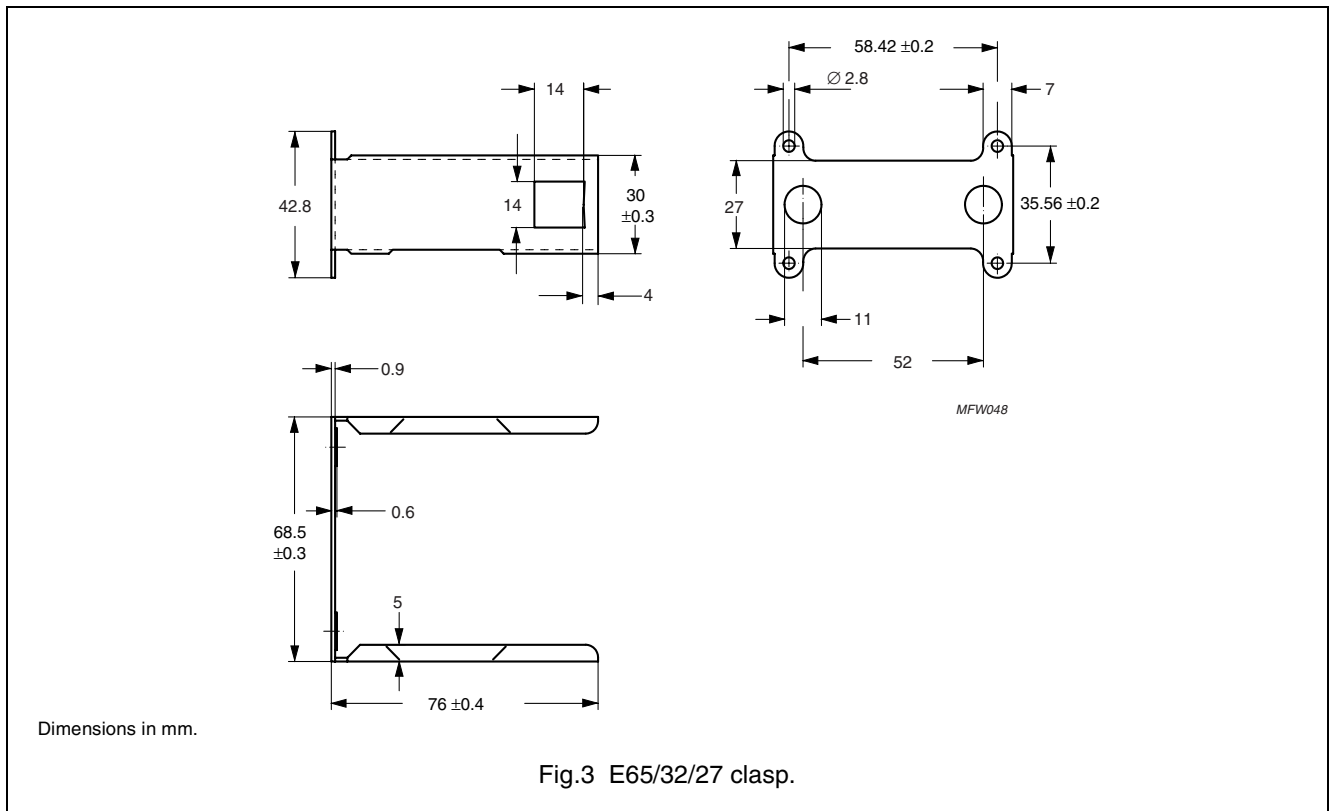



**DATA SHEET STATUS DEFINITIONS**

DATA SHEET STATUS	PRODUCT STATUS	DEFINITIONS
Preliminary specification	Development	This data sheet contains preliminary data. Ferroxcube reserves the right to make changes at any time without notice in order to improve design and supply the best possible product.
Product specification	Production	This data sheet contains final specifications. Ferroxcube reserves the right to make changes at any time without notice in order to improve design and supply the best possible product.

**DISCLAIMER**

**Life support applications** — These products are not designed for use in life support appliances, devices, or systems where malfunction of these products can reasonably be expected to result in personal injury. Ferroxcube customers using or selling these products for use in such applications do so at their own risk and agree to fully indemnify Ferroxcube for any damages resulting from such application.

**PRODUCT STATUS DEFINITIONS**

STATUS	INDICATION	DEFINITION
<b>Prototype</b>		These are products that have been made as development samples for the purposes of technical evaluation only. The data for these types is provisional and is subject to change.
<b>Design-in</b>		These products are recommended for new designs.
<b>Preferred</b>		These products are recommended for use in current designs and are available via our sales channels.
<b>Support</b>		These products are <b>not</b> recommended for new designs and may not be available through all of our sales channels. Customers are advised to check for availability.