

DATA SHEET

PTS14/8

**PT, PTS, PTS/I cores and
accessories**

Supersedes data of September 2004

2008 Sep 01



FERROXCUBE
A YAGEO COMPANY

CORE SETS

Effective core parameters

SYMBOL	PARAMETER	VALUE	UNIT
$\Sigma(l/A)$	core factor (C1)	1.02	mm ⁻¹
V_e	effective volume	495	mm ³
l_e	effective length	22.5	mm
A_e	effective area	22.0	mm ²
A_{min}	minimum area	19.9	mm ²
m	mass of set	≈ 2.5	g

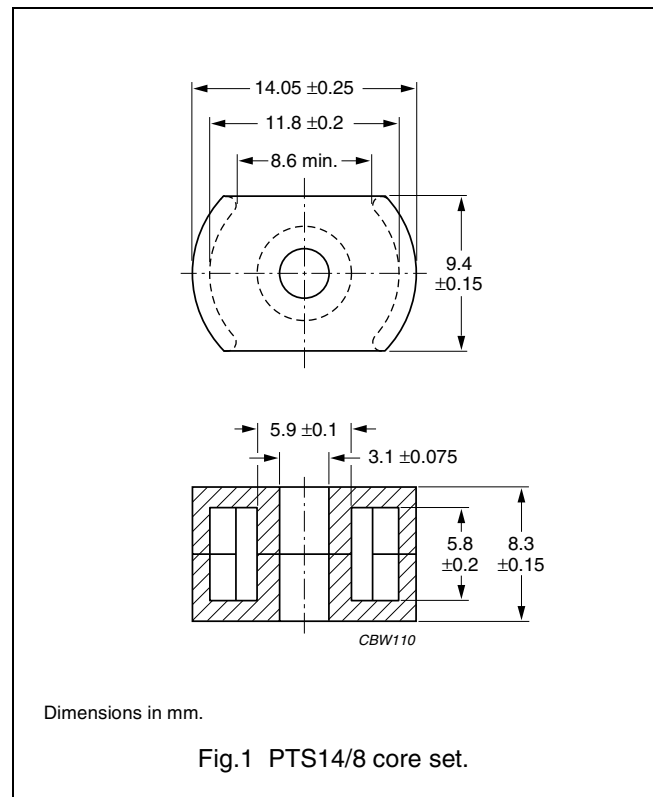

Core sets for general purpose transformers and power applications

Clamping force for A_L measurements, 15 ± 15 N.

GRADE	A_L (nH)	μ_e	AIR GAP (μ m)	TYPE NUMBER
3C81	63 ± 3%	≈ 51	≈ 590	PTS14/8-3C81-A63
	100 ± 3%	≈ 81	≈ 340	PTS14/8-3C81-A100
	160 ± 3%	≈ 130	≈ 190	PTS14/8-3C81-A160
	250 ± 3%	≈ 204	≈ 110	PTS14/8-3C81-A250
	315 ± 5%	≈ 257	≈ 90	PTS14/8-3C81-A315
	2330 ± 25%	≈ 1900	≈ 0	PTS14/8-3C81
3C91 <small>des</small>	2330 ± 25%	≈ 1900	≈ 0	PTS14/8-3C91
3F3	63 ± 3%	≈ 51	≈ 590	PTS14/8-3F3-A63
	100 ± 3%	≈ 81	≈ 340	PTS14/8-3F3-A100
	160 ± 3%	≈ 130	≈ 190	PTS14/8-3F3-A160
	250 ± 3%	≈ 204	≈ 110	PTS14/8-3F3-A250
	315 ± 5%	≈ 257	≈ 90	PTS14/8-3F3-A315
	1625 ± 25%	≈ 1320	≈ 0	PTS14/8-3F3

PT, PTS, PTS/I cores and accessories

PTS14/8
(1408THS)**Core sets of high permeability grades**Clamping force for A_L measurements, 15 ± 5 N.

GRADE	A_L (nH)	μ_e	AIR GAP (μm)	TYPE NUMBER
3E27	$4370 \pm 25\%$	≈ 3540	≈ 0	PTS14/8-3E27

Properties of core sets under power conditions

GRADE	B (mT) at	CORE LOSS (W) at			
	H = 250 A/m; f = 25 kHz; T = 100 °C	f = 25 kHz; B = 200 mT; T = 100 °C	f = 100 kHz; B = 100 mT; T = 100 °C	f = 100 kHz; B = 200 mT; T = 100 °C	f = 400 kHz; B = 50 mT; T = 100 °C
3C81	≥ 320	≤ 0.1	–	–	–
3C91	≥ 320	–	$\leq 0.026^{(1)}$	$\leq 0.19^{(1)}$	–
3F3	≥ 315	–	≤ 0.054	–	≤ 0.94

Note

1. Measured at 60 °C.

BOBBINS AND ACCESSORIES

For coil formers, winding data and mounting parts, see data sheet, "P14/8" and "PT14/8", but "area product" is different.

Winding data and area product (for PTS14/8) for 6-pins PT14/8 coil former

NUMBER OF SECTIONS	MINIMUM WINDING AREA (mm ²)	NOMINAL WINDING WIDTH (mm)	AVERAGE LENGTH OF TURN (mm)	AREA PRODUCT $A_e \times A_w$ (mm ⁴)	TYPE NUMBER
1	7.9	4.1	29.2	174	CPV-PT14/8-1S-6P

Winding data and area product (for PTS14/8) for CP-P14/8 coil former

NUMBER OF SECTIONS	WINDING AREA (mm ²)	MINIMUM WINDING WIDTH (mm)	AVERAGE LENGTH OF TURN (mm)	AREA PRODUCT $A_e \times A_w$ (mm ⁴)	TYPE NUMBER
1	8.8	4.1	28.9	194	CP-P14/8-1S
2	2×4.0	2×1.85	28.9	2×88.0	CP-P14/8-2S

PT, PTS, PTS/I cores and accessories

PTS14/8
(1408THS)

Winding data and area product (for PTS14/8) for CP-P14/8-A coil former

NUMBER OF SECTIONS	MINIMUM WINDING AREA (mm ²)	NOMINAL WINDING WIDTH (mm)	AVERAGE LENGTH OF TURN (mm)	AREA PRODUCT Ae x Aw (mm ⁴)	TYPE NUMBER
1	9.4	4.5	29.0	207	CP-P14/8-1S-A
2	2 x 4.32	2 x 2.0	29.0	2 x 95.0	CP-P14/8-2S-A
3	3 x 2.19	3 x 1.2	29.0	3 x 48.2	CP-P14/8-3S-A

Winding data and area product (for PTS14/8) for 4-pins P14/8 coil former for PCB mounting

NUMBER OF SECTIONS	MINIMUM WINDING AREA (mm ²)	NOMINAL WINDING WIDTH (mm)	AVERAGE LENGTH OF TURN (mm)	LENGTH OF PINS (mm)	AREA PRODUCT Ae x Aw (mm ⁴)	TYPE NUMBER
1	8.65	4.4	29.0	4.4	190	CPV-P14/8-1S-4SPD
1	8.65	4.4	29.0	6.8	190	CPV-P14/8-1S-4SPDL
2	2 x 3.87	2 x 2.0	29.0	4.4	2 x 85.1	CPV-P14/8-2S-4SPD
2	2 x 3.87	2 x 2.0	29.0	6.8	2 x 85.1	CPV-P14/8-2S-4SPDL

Winding data and area product (for PTS14/8) for 6-pins P14/8 coil former for PCB mounting

NUMBER OF SECTIONS	MINIMUM WINDING AREA (mm ²)	NOMINAL WINDING WIDTH (mm)	AVERAGE LENGTH OF TURN (mm)	LENGTH OF PINS (mm)	AREA PRODUCT Ae x Aw (mm ⁴)	TYPE NUMBER
1	8.65	4.4	29.0	4.4	190	CPV-P14/8-1S-6PD
1	8.65	4.4	29.0	6.8	190	CPV-P14/8-1S-6PDL
2	2 x 3.87	2 x 2.0	29.0	4.4	2 x 85.1	CPV-P14/8-2S-6PD
2	2 x 3.87	2 x 2.0	29.0	6.8	2 x 85.1	CPV-P14/8-2S-6PDL

DATA SHEET STATUS DEFINITIONS

DATA SHEET STATUS	PRODUCT STATUS	DEFINITIONS
Preliminary specification	Development	This data sheet contains preliminary data. Ferroxcube reserves the right to make changes at any time without notice in order to improve design and supply the best possible product.
Product specification	Production	This data sheet contains final specifications. Ferroxcube reserves the right to make changes at any time without notice in order to improve design and supply the best possible product.

DISCLAIMER

Life support applications — These products are not designed for use in life support appliances, devices, or systems where malfunction of these products can reasonably be expected to result in personal injury. Ferroxcube customers using or selling these products for use in such applications do so at their own risk and agree to fully indemnify Ferroxcube for any damages resulting from such application.

PRODUCT STATUS DEFINITIONS

STATUS	INDICATION	DEFINITION
Prototype		These are products that have been made as development samples for the purposes of technical evaluation only. The data for these types is provisional and is subject to change.
Design-in		These products are recommended for new designs.
Preferred		These products are recommended for use in current designs and are available via our sales channels.
Support		These products are not recommended for new designs and may not be available through all of our sales channels. Customers are advised to check for availability.