

# C08 Series Current Sensor

The C08 series current sensor is a Hall-Effect sensor which is sensitive to the flux density applied orthogonally to the IC surface, and provides an analog output voltage proportional to the applied magnetic flux density. It is particularly adapted for high speed applications such as inverters and converters where fast response time due to fast switching is required.

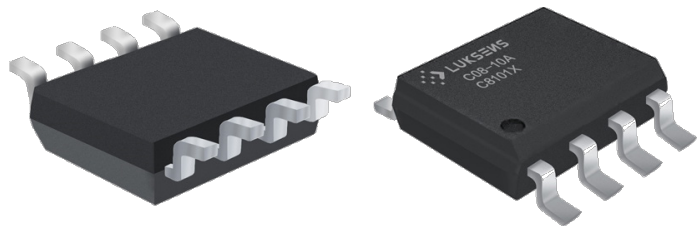

## Features

- Factory trimmed sensitivity sensor
- Flexible supply voltage with factory selectable 5V or 3.3V mode
- Superior temperature stability and linearity
- Compact size for applications with limited space
- RoHs compliance (Lead-Free)

## Applications

- High voltage traction motor inverter
- 48V boost recuperation inverter
- DCDC converter
- Smart battery junction boxes
- Smart fuse overcurrent detection
- Redundant monitoring of battery management system (BMS)

## Advantages

- Accurately measures AC, DC and pulse currents
- Fast response 4 $\mu$ s, minimal noise output
- No insertion losses
- Improving noise immunity using differential hall technology
- Excellent current overload capacity
- Very low thermal drift for wide temperature range

## Standards

- EN 55014-1: 2017
- EN 55014-2: 2015
- EN 50178: 1998
- EN 61000-4 Series
- IEC 60068-2 Series

## Absolute maximum ratings

Symbol	Parameter	Min.	Max.	Unit
$V_{DD\ max.}$	Maximum supply voltage (not destructive)	-0.3	6.5	V
$I_{PM}$	Maximum measuring current	-30	30	A
$T_A$	Ambient operating temperature	-40	125	°C
$T_S$	Storage temperature range	-40	150	°C
$V_{ESD-HBM}$	ESD sensitivity HBM (Human Body Model)	8		kV

Stresses above these ratings may cause permanent damage. Exposure to absolute maximum ratings for extended periods may degrade reliability.

## Specifications ( $T_A = 25^\circ\text{C}$ , $V_{DD} = 3.3\text{V}/5.0\text{V}$ )

Symbol	Parameter	Test condition	Min.	Typ.	Max.	Unit
$V_{DD}$	Supply voltage		3	3.3	3.6	V
			4.5	5	5.5	
$I_C$	Current consumption	$I_P=0\text{A}$ without load, $V_{DD}=5\text{V}$		12	15	mA
		$I_P=0\text{A}$ without load, $V_{DD}=3.3\text{V}$		7.5	8	
$I_{PN}$	Current nominal measuring range	C08-10A	-10		10	A
		C08-20A	-20		20	
		C08-30A	-30		30	
$R_{IP}$	Primary conductor resistance	$T_A=25^\circ\text{C}$		1.2		mΩ
$T_{PO}$	Power-On time			1		ms
$I_{SHORT}$	Output short-circuit current			25		mA
$R_L$	Output load resistance	$V_{OUT}$ to GND	10			kΩ
$C_L$	Output load capacitance	$V_{OUT}$ to GND			10	nF
$V_{REF}$	Internal reference voltage	$I_P=0\text{A}$ , $V_{DD}=5\text{V}$	2.49	2.5	2.51	V
		$I_P=0\text{A}$ , $V_{DD}=3.3\text{V}$	1.64	1.65	1.66	

## Specifications ( $T_A = 25^\circ\text{C}$ , $V_{DD} = 3.3\text{V}/5.0\text{V}$ )

Symbol	Parameter	Test condition	Min.	Typ.	Max.	Unit
$V_o$	$V_{out}(@I_p=0A)$	$I_p=0A$		$V_{DD}/2$		V
$V_{OE}$	Offset voltage	$I_p=0A$	-10	$\pm 6$	10	mV
$T_{CVO}$	Temperature coefficient of $V_o$ @ $I_p=0A$ $T_A=-40^\circ\text{C} \dots 125^\circ\text{C}$		-12		12	mV
$G$	Nominal sensitivity (customized available)	C08-10A		200		mV/A
		C08-20A		100		
		C08-30A		66		
		C08-10A33		132		
		C08-20A33		66.67		
		C08-30A33		44		
$T_{CG}$	Temperature coefficient of G	$T_A = -40^\circ\text{C} \dots 125^\circ\text{C}$		$\pm 2.5$		%
$\epsilon_L$	Non-linearity error	$\pm I_{PN}$ without offset		$\pm 0.2$		%/ $I_{PN}$
<b>BW</b>	Frequency bandwidth (-3dB)			400		kHz
$T_R$	Step response to 90% $I_{PN}$	(Design target)		4		$\mu\text{s}$

## Insulation characteristics

Symbol	Parameter	Value	Unit	Comment
$V_{SURGE}$	Dielectric surge voltage	6000	V	In compliance to IEC 61000-4-5 1.2 $\mu\text{s}$ (rise) / 50 $\mu\text{s}$ (width)
$R_{ISO}$	Isolation resistance @500VDC	3000	Vrms	solation resistance test for 60 seconds in compliance to UL 62368-1; production-tested at 3.6kV for 1 second; partial discharge verification less than 5pC
$V_{UVBT}$	Working voltage for basic isolation	424	Vrms	Maximum approved working voltage for basic (single)
		600	$V_{DC}$	isolation according to UL 60950-1 and UL 62368-1
<b>CMTI</b>	Common mode field rejection	>100	V/ns	
<b>D-CLE</b>	Clearance	4	mm	Shortest distance through air
<b>D-CRD</b>	Creepage distance	4	mm	Shortest distance through body

# PCB footprint (mm, general tolerance: $\pm 0.05\text{mm}$ )

## PCB Layout

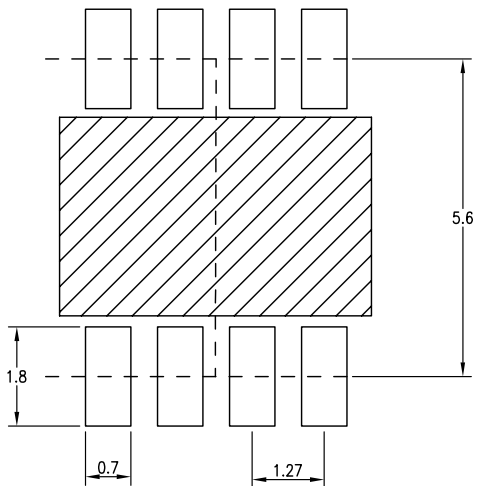

### Note:

Maximum soldering temperature 260°C 10s

Maximum PCB thickness 2.4mm

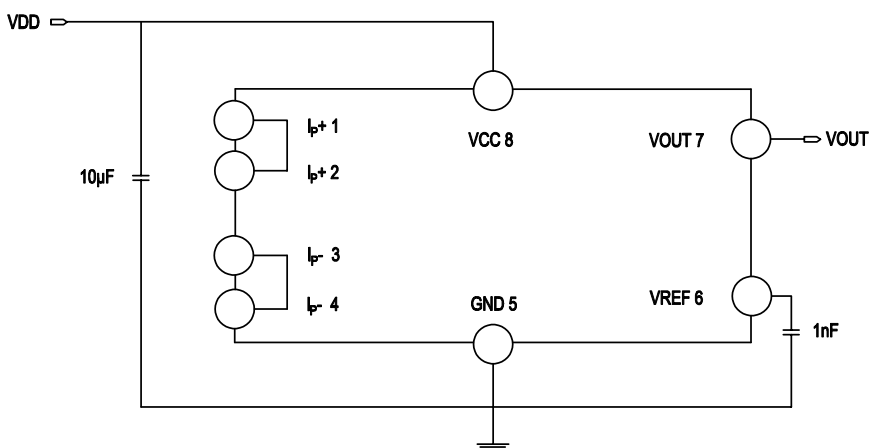

## Dimension (mm)

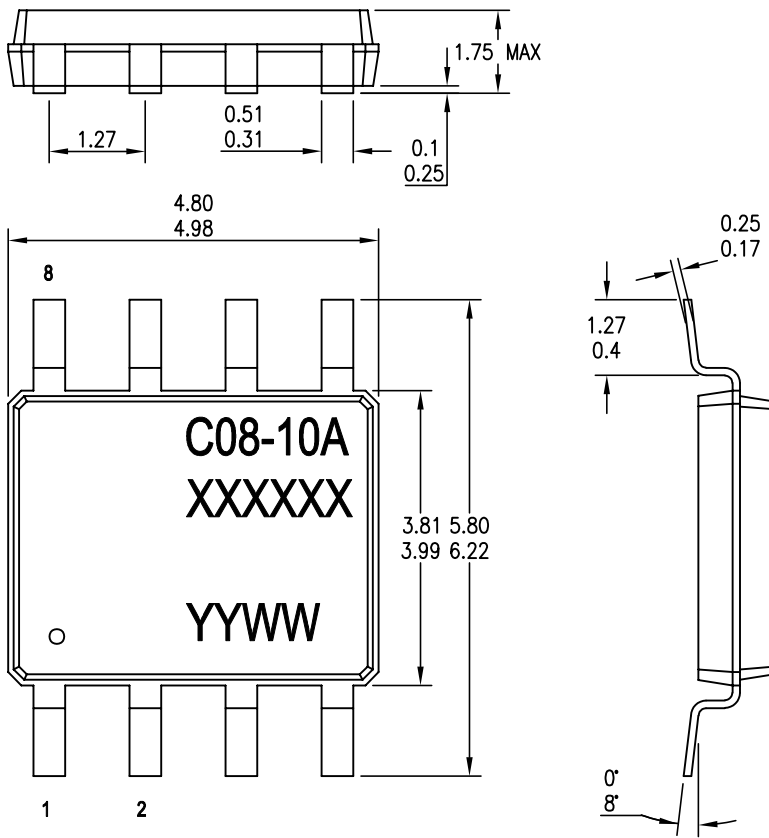

# Name Guide Description

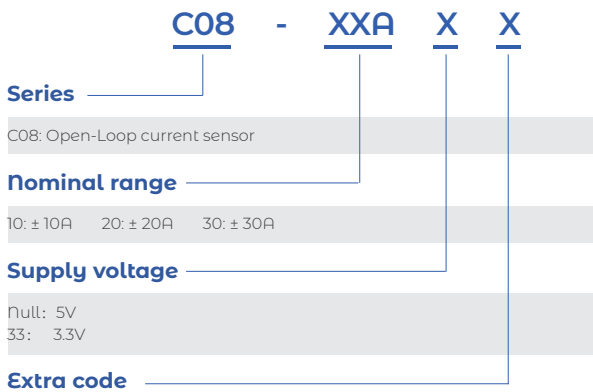

## Notes

The content of this document is subject to revision without notice. Luksens shall have no liability for any error or damage of any kind resulting from the use of this document.

# Safety and Environment



The product is to be installed by manufacturer trained personnel or competent person trained in accordance with manufacturer installation instructions.

With respect to applicable standards IEC 61010-1/ EN 61010-1 *safety requirements for electrical equipment for measurement, control and laboratory use part 1 general requirements*, the product should be used in limited energy secondary circuits.



## Risk of electrical shock

Certain parts of the module can carry hazardous voltage during the operation process of the product because hazardous live voltage of primary conductor, power supply occurs, injury and/or serious damage will be caused if this warning is ignored.

Conducting parts must be inaccessible after installation of the product. Additional protection including shield or protective housing could be used according to IEC 60664 Insulation coordination for equipment within low-voltage supply systems.

Disconnection of the main supply will protect against possible injury and serious damage.



## ESD protection

Damage from an ESD event will occur if the personnel is not well grounded when handling.

## Important notice

Luksens reserves the right to make changes to or discontinue any product or service identified in this publication without notice. Luksens advises its customers to obtain the latest version of the relevant information to verify, before placing any orders. The information included herein is believed to be accurate and reliable. However, since additional design, measure, production, quality control take effect in the end product, therefore Luksens shall have no liability for any potential hazards, damages, injuries or less of life resulting from the end product.

Luksens products are not to be used in any equipment or system, including but not limited to life support equipment or systems, where failure of Luksens products may cause bodily harm.